

## IMTEC INSULATED SINGLE DOOR WITHOUT TUBE PANEL (MAX OPERATING 1800°)



**BTA IMTEC**  
FLEXISEAL Access Doors

### OVERVIEW

Boiler Tube Company of America/Imtec has been manufacturing Access Doors for the power industry since 1984. We have over 20,000 units installed and have experience in all areas of the power plant from the boiler to the stack.

Imtec's boiler doors without tube panels are available with a max operating temperature of 1800 degrees. The boiler door must withstand high operating and excursion gas temperatures. Therefore, on boiler doors type BM the inner side of the door plate is equipped with high efficiency insulation supported by interior shelves and all contained in a protective insulation pan which, for flexibility and heat expandability, is made with slots and in movable sections from heat resistant steel. When installed, this insulation pan must be closely surrounded by either refractory, a steel casing or water wall tubes shaped in a fashion to match the conical shape of the insulation pan.

The FLEXISEAL doors have one or more yokes with closing screws that act on center point(s) of the door. This flexes the door plate toward the interior and assures a tight seal with the gasket. When opening the door, special safety features in the latch and screw mechanism(s) will assure that the latch pin cannot be removed easily until the door plate with its gasket is safely retracted from the sealing surface on the frame plate, thereby revealing any dangerous internal pressure and also preventing damage to the gasket.



Imtec Insulated Single Door  
Without Tube Panel

### FEATURES/BENEFITS

#### Common

- Safety mechanism impedes release of the latch on a door with pressure
- Open & close in seconds without tools
- Adequate sizes for easy entry
- Safety latch prevents injury and entrapment
- Heavy, durable, dependable design
- Quick, easy installation- new or retrofit
- All stainless fasteners
- No tube panel required



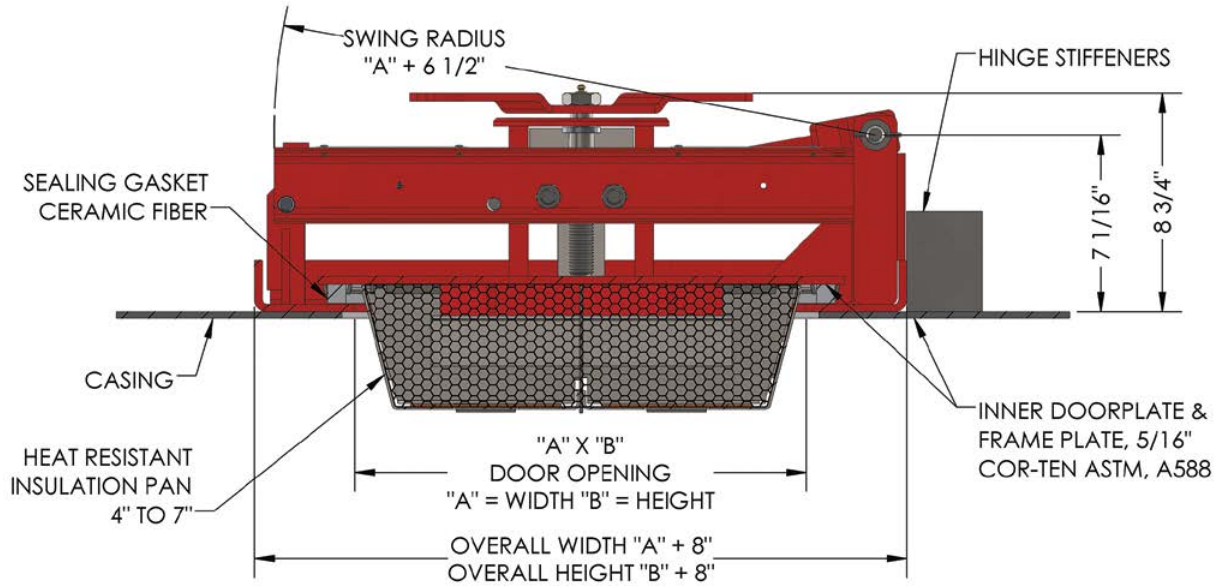

**DOOR TYPE BM**

DOOR TYPE	BM
Typical Applications	Boiler Super Heat Section, Back Pass, Cool Apexes
Operating Temperature	1800°F
Max. Excursion	2000°F
Door Size Width x Height Of Door Opening	Code Numbers For Standard Sizes (Other Sizes Available)
18" X 24"	BM-1824.5-1C
18" X 30"	BM-1830.5-1C
24" X 24"	BM-2424.5-1C
24" X 30"	BM-2430.5-1C
24" X 32"	BM-2432.5-1C
24" X 36"	BM-2436.5-2C
24" X 48"	BM-2448.5-2C
30" X 60"	BM-3060.5-2C

For further information on Boiler Tube Company of America/Imtec's patented (US 5,158,043, US 4,574,973, US 4,685,586, US 6,412,221, US 7,389,610. Other patents pending) Insulated Single Door without Tube Panel, please contact:

**Russell McMakin, 864-345-5984**  
[rmcmakin@boilertubes.com](mailto:rmcmakin@boilertubes.com)

**SAFETY<sup>3</sup> PEOPLE. POWER. PROJECTS.**

We're giving safety the third degree.

Babcock Power Inc. and its subsidiaries place the safety, health and security of our people at the core of our company values. Our team is our most valuable resource, generating solutions everyday to deliver safe, clean, reliable energy globally. With a keen focus on safety, Babcock Power Inc. conducts business in a manner that protects our people, our customers and the environment. From innovation to generation, we are proud of our award-winning safety record and are committed to operating with integrity and excellence.

The data contained herein is solely for your information and is not offered, or to be construed, as a warranty or contractual responsibility.

© Boiler Tube Company of America, 2018

